

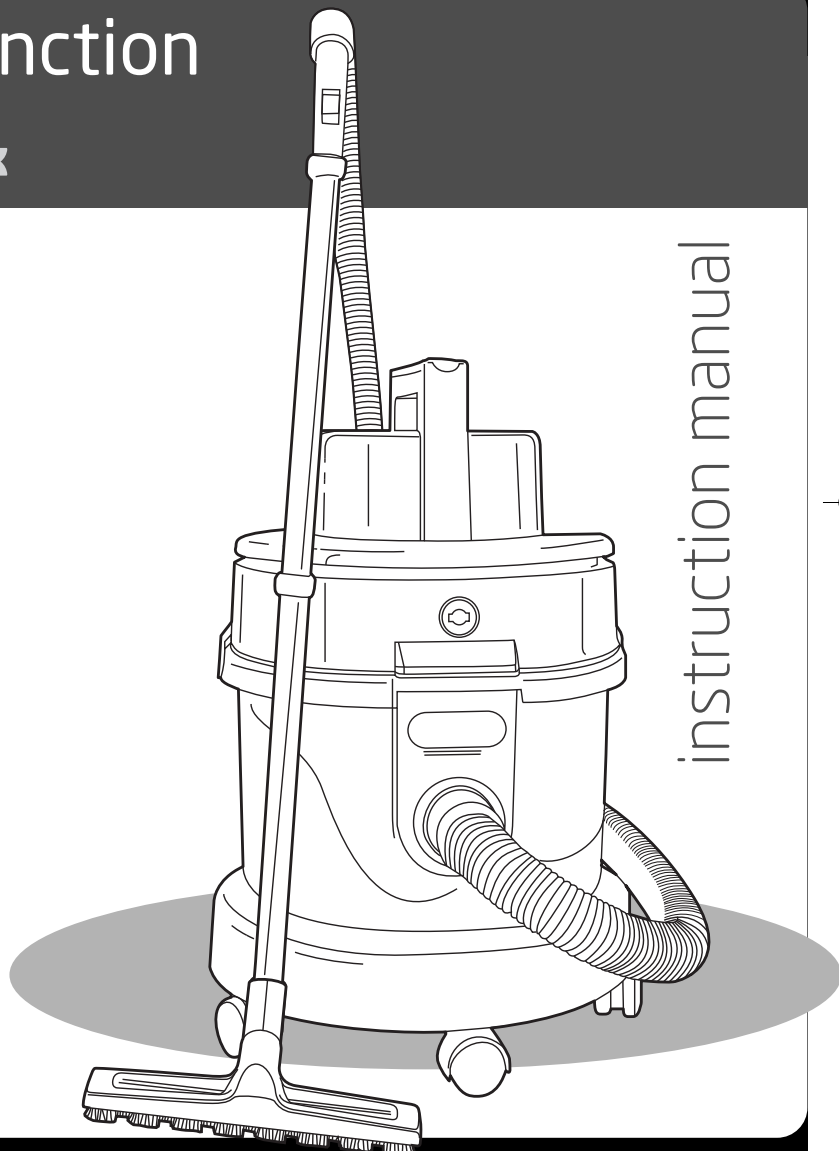

Vax careline
0870 6061248

Multifunction pet[®]vax

Vax model number:
6141



instruction manual

www.vax.co.uk

Please read carefully before using this cleaner.
Always fully extend the mains cable before use.
Retain for future reference.

www.vax.co.uk

1. Diagram

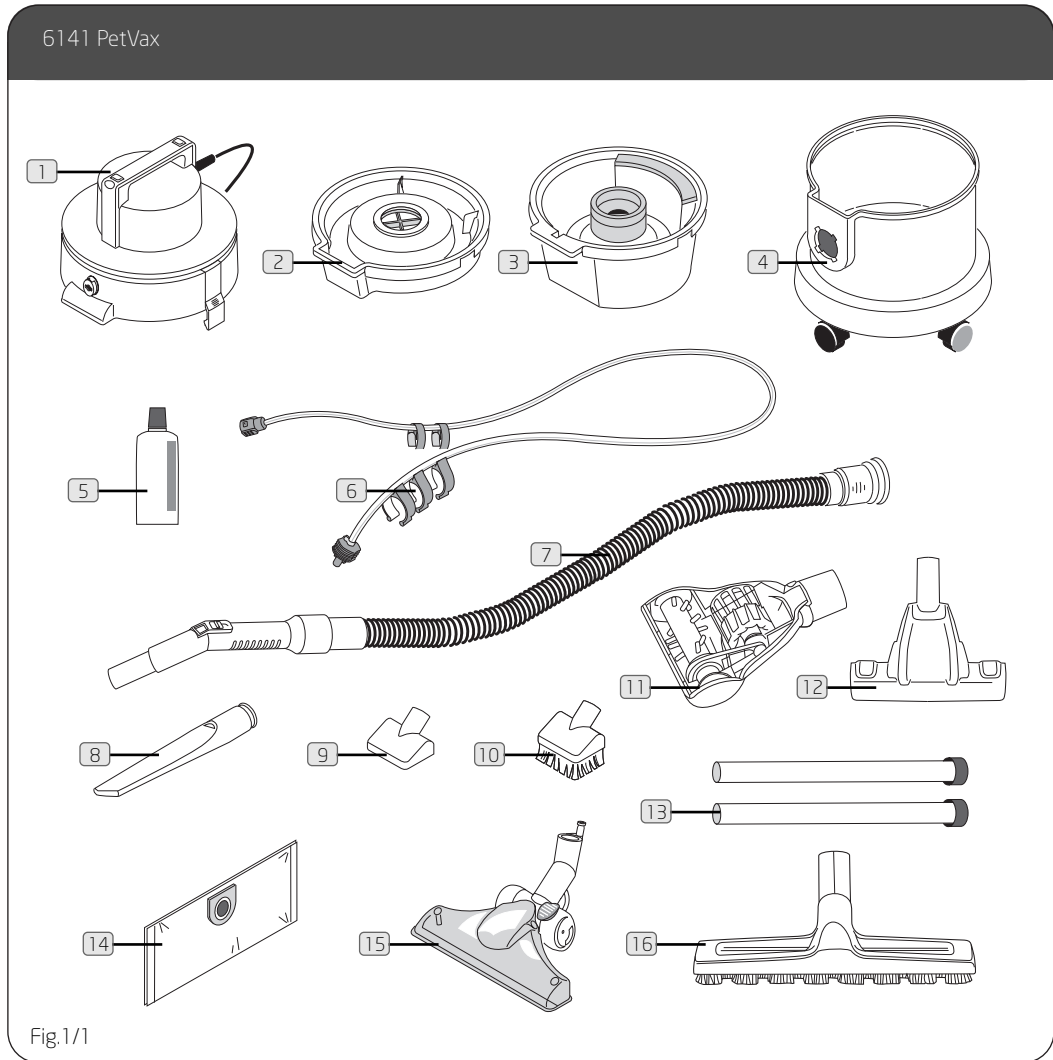

- | | |
|---|-------------------------------|
| 1 Motor unit | 9 Upholstery / stair tool |
| 2 Cone filter unit | 10 Dusting brush |
| 3 Clean water bucket | 11 TurboTool |
| 4 Dirty water bucket | 12 TurboBrush |
| 5 'For Pets' AAA carpet cleaning solution | 13 Extension tubes (x2) |
| 6 Water delivery tube (+ 5 clips) | 14 Dust bags (x3) |
| 7 Hose and hand grip | 15 Fibreflow carpet wash head |
| 8 Crevice tool | 16 Hard floor tool |

2 parts overview

2. Safety Information

FOR HOUSEHOLD USE ONLY.

When using the vacuum cleaner, basic safety precautions should always be observed, including the following:

1. Do not leave the carpet washer unattended when plugged in. Unplug it from socket when not in use.
2. To prevent electric shock do not use outdoors.
3. Not to be used as a toy. Children should be supervised to ensure that they do not play with the appliance.
4. This appliance is not intended for use by persons (including children) with reduced physical, sensory or mental capabilities, or lack of experience and knowledge, unless they have been given supervision or instruction concerning the use of the appliance by a person responsible for their safety.
5. Use only as described in this manual.
6. Do not use with a damaged cord or plug. If the supply cord and/or plug is damaged, they must be replaced by the manufacturer, a Vax Service Agent or similarly qualified persons in order to avoid hazard.
7. Do not pull or carry by the cord, use the cord as a handle, allow the cord to come into contact with hot or sharp surfaces or close a door on the cord.
8. Do not unplug by pulling on the cord.
9. Do not handle the plug or carpet washer with wet hands.
10. Do not put any objects into openings or operate with openings blocked, keep them free of anything that may reduce airflow.
11. Keep hair, loose clothing, fingers and all parts of the body away from openings and moving parts.
12. Do not use the carpet washer on any glowing, burning or smoking particles.
13. Do not use without the solution tank and dirty water tank in place.
14. Do not use the vacuum without the dust bag in place.
15. Turn off all controls before unplugging.
16. Do not use to pick up flammable or combustible liquids such as petrol, or use in areas where they may be present.
17. Keep the unit on the floor.
18. Do not use an extension cord.
19. Do not attempt to remove blockages with sharp objects as they may cause damage.
20. Store indoors put away after use to prevent tripping accidents.

21. Using improper voltage may result in damage to the motor and possible injury to the user. The correct voltage is listed on the rating label.
22. A hazard may occur if the carpet washer runs over the power supply cord.
23. To prevent dirty water from running into motor, do not hold the appliance upside-down or lay on its side. Use appliance in normal vacuuming position.
24. Use extra care when cleaning on stairs.
25. Do not carry appliance while motor is running.

NOTE: Carpets should be dry vacuumed thoroughly before washing.

NOTE: The unit must be unplugged from the mains socket outlet after use, and before cleaning or maintaining the unit.



IMPORTANT: This unit is not intended for commercial use.

PLEASE KEEP THESE INSTRUCTIONS FOR FURTHER USE.

3. Initial Set Up

! **IMPORTANT:** Always unplug the vacuum cleaner from the electrical outlet before assembling or removing the accessories.

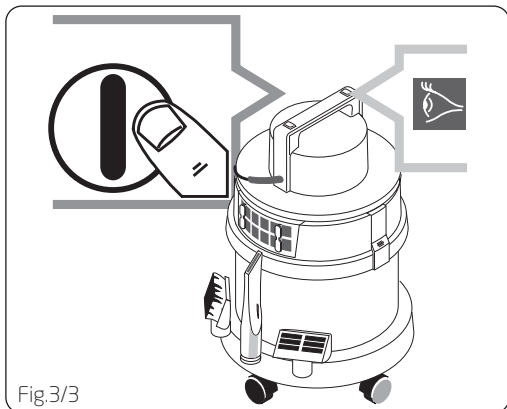
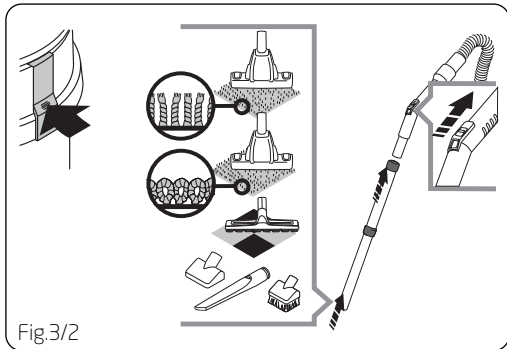
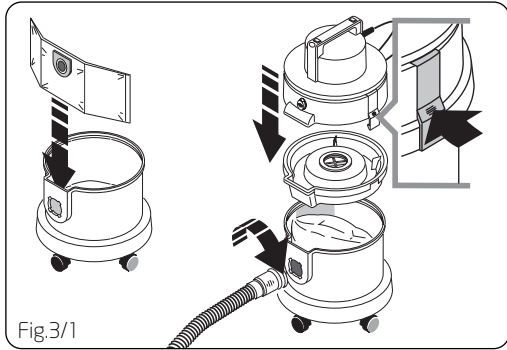

4. Preparing the Unit for Carpet Washing

! **IMPORTANT:** Use only Vax AAA carpet cleaner with this machine. Using other cleaning solutions may cause excessive foaming and damage the unit. Using other soaps will void your warranty.

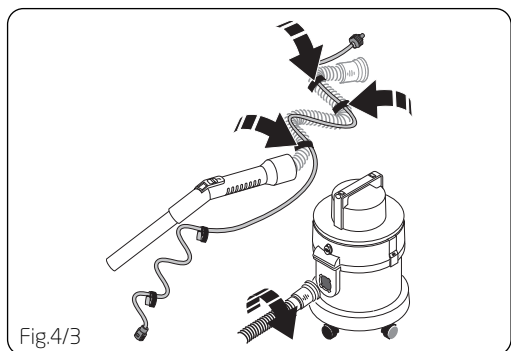
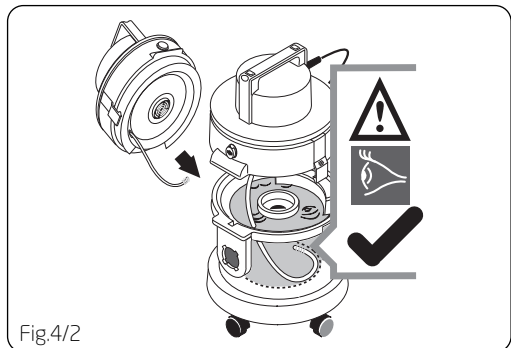
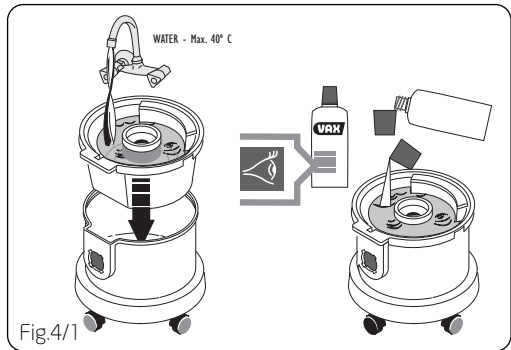

5. Carpet Washing Instructions

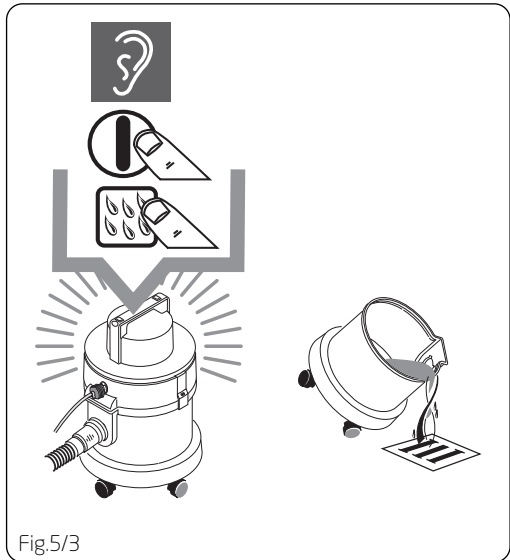
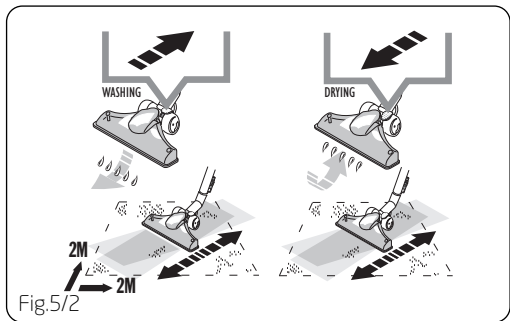
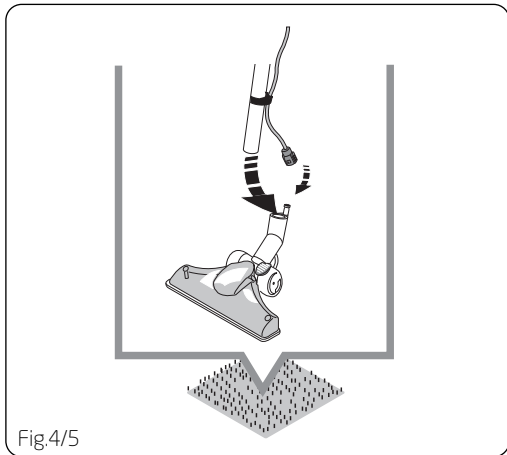
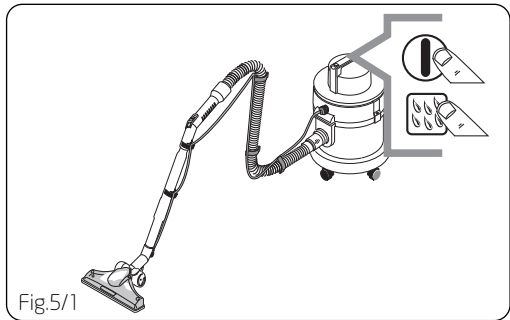
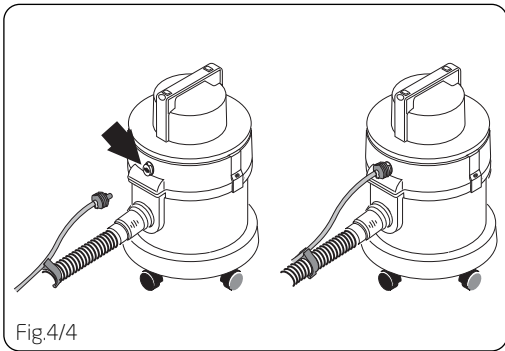

6. Cleaning Up After Use

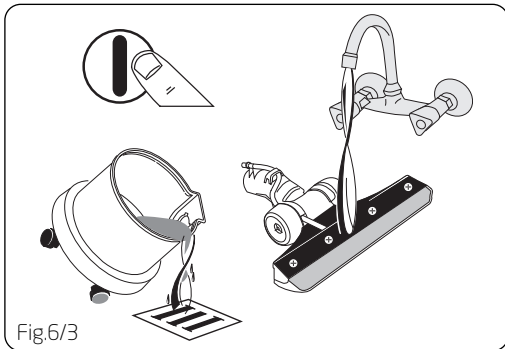
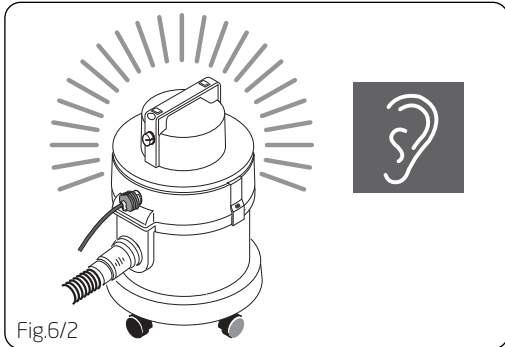
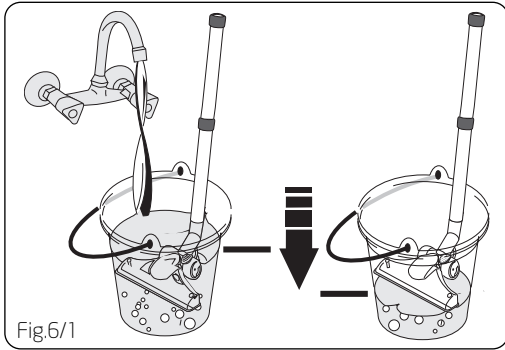

7. Maintaining Your Unit

Replace the cone filter regularly (Fig.7/1).

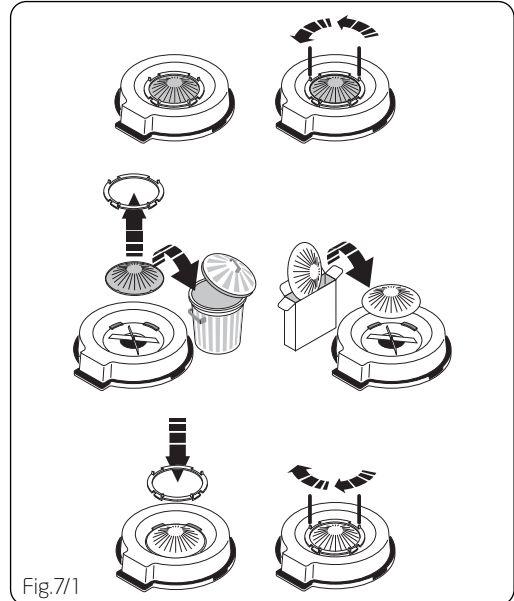

Wash out the blue filter regularly and replace occasionally (Fig.7/2).

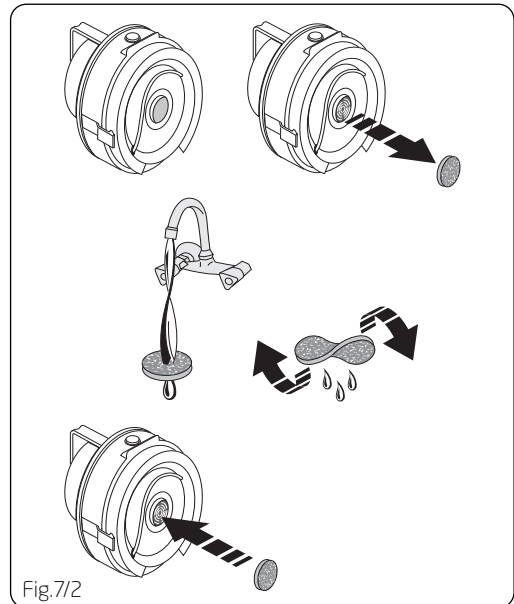

8. Clearing Blockages

⚠ WARNING: To reduce the risk of electric shock, the power cord must be disconnected before performing maintenance or troubleshooting checks.

Turn the vacuum cleaner off and unplug from the electrical outlet.

The flexible hose can be disconnected from the vacuum cleaner by rotating the hose connector 90 degrees anti-clockwise and pulling away from the machine. Remove any blockages found then reconnect the hose securely.

Removing debris from the TurboTool

Switch the vacuum cleaner off and disconnect the power plug from the electrical outlet.

Rotate the locking ring 180° (Fig.8/1).

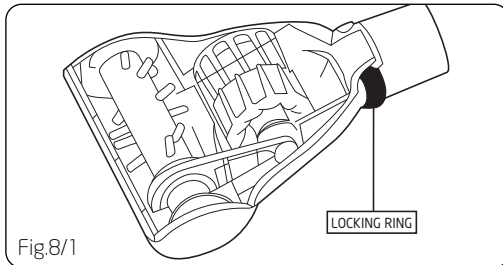

Lift the top cover off and remove any blockage (Fig.8/2).

To re-assemble, ensure that the tabs are engaged. Pivot the lower housing closed and rotate the locking ring 180° (Fig.8/2).

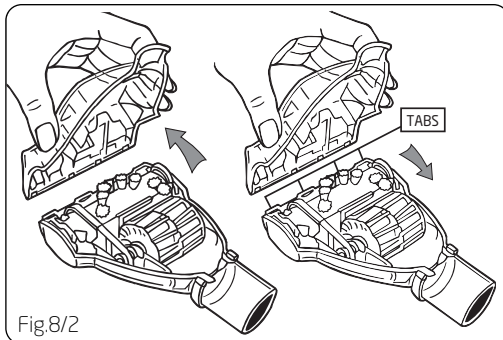

Removing debris from the TurboBrush

The brushbar will stop rotating if it is blocked during operation by vacuuming up foreign objects, or if strands of carpet are wrapped around it.

Switch the vacuum cleaner off and disconnect the power plug from the electrical outlet.

Lay the TurboBrush floor head on a flat surface and turn over to expose the brushbar. Using a pair of scissors, cut through any threads or hairs caught by the brushbar that have wrapped around the guides (Fig.8/3).

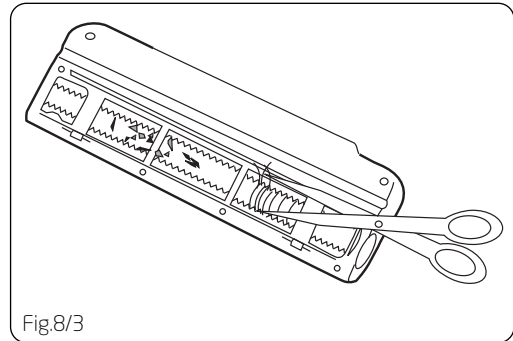

9. Troubleshooting

⚠ WARNING: To reduce the risk of personal injury, unplug the vacuum cleaner before performing maintenance or troubleshooting checks.

PROBLEM: Vacuum cleaner won't run

Cause: Not properly plugged into electrical outlet.

Solution: Plug unit in firmly.

Cause: Vacuum cleaner not turned on.

Solution: Press on/off button.

Cause: No electricity in the electrical outlet.

Solution: Check fuse or breaker.

Cause: Blown fuse / tripped breaker.

Solution: Reset circuit breaker or replace fuse.

Cause: Motor thermostat has tripped.

Solution: Switch off and unplug the vacuum cleaner. Leave for one (1) hour. See page 3.

PROBLEM: Cleaner won't pick up/loss of suction.

Cause: Dust bag not installed correctly.

Solution: Review dust bag removal and replacement.

Cause: Dust bag full or blocked.

Solution: Replace dust bag.

Cause: Clogged filter.

Solution: Remove filter and clean.

Cause: Blockage in hose.

Solution: Disconnect hose, remove the obstruction then re-fit.

PROBLEM: Accessories won't pick up.

Cause: Accessories not attached correctly.

Solution: Refer to page 7 for fitting information.

PROBLEM: Dust escaping from the vacuum cleaner.

Cause: Dust bag full.

Solution: Dispose of dust bag, replace with a new one.

Cause: Dust bag not installed correctly.

Solution: Review dust bag removal and replacement.

Cause: Hose not installed correctly.

Solution: Review hose installation.

Cause: Filter not installed completely.

Solution: Review filter removal and replacement.

10. UK Service & Help

Vax Care 0870 6061248 (UK only)

Monday-Friday 9.00am to 5.00pm.

An answerphone is available outside of these hours. Any queries or concerns about using the Vax, call the Vax Careline. Calls are charged at the UK national rate.

Please make a note of the serial number and model number of the carpet cleaner before calling. There are over 400 approved Vax Service Agents in the UK. For the nearest Service Agent, please call the Vax Careline.

www.vax.co.uk

11. Technical Specification

| | |
|--------------|--|
| Voltage: | 220-240V ~50Hz |
| Wattage: | 1300W |
| Capacity: | Clean water tank: 4 litres Dirty water tank: 8 litres |
| Filters: | Pre-motor filters Post-motor filter Cone filter |
| Cord length: | 7.5m |
| Weight: | 7.5kg |

Subject to technical change without notice.



www.vax.co.uk

This page has been left intentionally blank

This page has been left intentionally blank



EEC STATEMENT OF COMPLIANCE

Manufacturer/EEC importer: Vax Limited, hereby on our own responsibility, declare that the 6141 Multifunction Cleaner is manufactured in compliance with the following Directives:

Safety: 2006/95/EC Low Voltage Directive
EMC: 89/336/EEC Electromagnetic Compatibility Directive



Waste electrical products should not be disposed of with household waste. Please recycle where facilities exist. Check with your Local Authority or retailer for recycling advice.

Vax Ltd., Kingswood Road, Hampton Lovett, Droitwich, Worcestershire, WR9 0QH, UK
email: info@vax.co.uk - website: www.vax.co.uk