

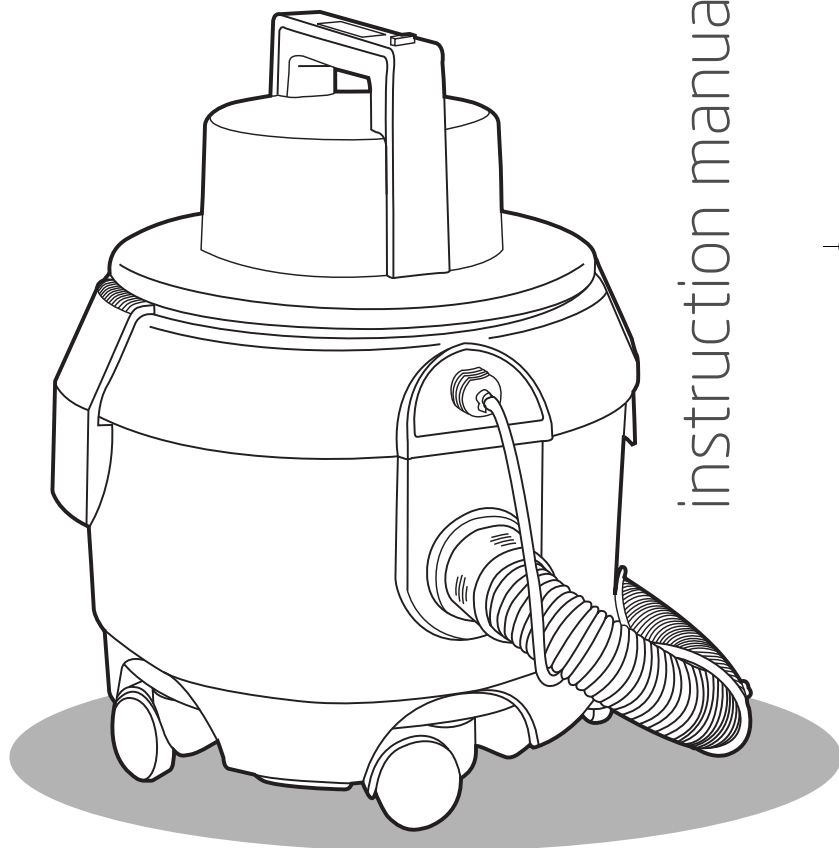

Vax careline  
0870 6061248

# Carpet washer Essentials

Vax model number:  
VEW-01



instruction manual

[www.vax.co.uk](http://www.vax.co.uk)

Please read carefully before using this cleaner.  
Always fully extend the mains cable before use.  
Retain for future reference.

# 1. Diagram

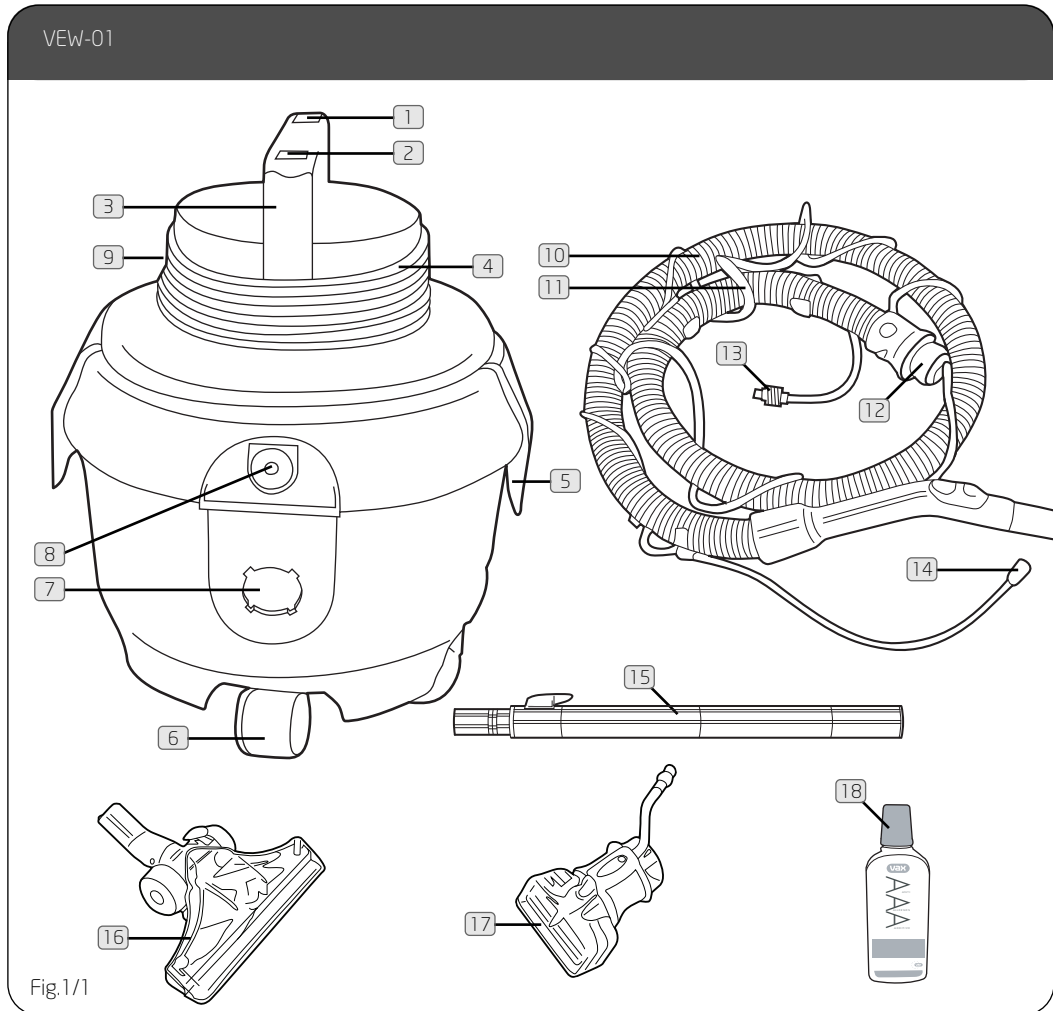

Fig.1/1

- |   |  |
|---|--|
| <ul style="list-style-type: none"> <li>1 Water pump button (green)</li> <li>2 Power button (red)</li> <li>3 Carry handle</li> <li>4 Power cord</li> <li>5 Container release clips</li> <li>6 Casters</li> <li>7 Hose connection port</li> <li>8 Solution tube port</li> <li>9 Exhaust filter</li> </ul> | <ul style="list-style-type: none"> <li>10 Hose</li> <li>11 Solution tube</li> <li>12 Hose connector</li> <li>13 Solution tube to machine connector</li> <li>14 Solution tube to wash head/upholstery tool connector</li> <li>15 Telescopic tube</li> <li>16 Fireflow carpet wash head</li> <li>17 Upholstery wash tool</li> <li>18 Vax AAA carpet cleaner</li> </ul> |
|---|--|

## 2 parts overview

## 2. Safety Information

### FOR HOUSEHOLD USE ONLY.

When using the vacuum cleaner, basic safety precautions should always be observed, including the following:

1. Do not leave the carpet washer unattended when plugged in. Unplug it from socket when not in use.
2. To prevent electric shock do not use outdoors.
3. Not to be used as a toy. Children should be supervised to ensure that they do not play with the appliance.
4. This appliance is not intended for use by persons (including children) with reduced physical, sensory or mental capabilities, or lack of experience and knowledge, unless they have been given supervision or instruction concerning the use of the appliance by a person responsible for their safety.
5. Use only as described in this manual.
6. Do not use with a damaged cord or plug. If the supply cord and/or plug is damaged, they must be replaced by the manufacturer, a Vax Service Agent or similarly qualified persons in order to avoid hazard.
7. Do not pull or carry by the cord, use the cord as a handle, allow the cord to come into contact with hot or sharp surfaces or close a door on the cord.
8. Do not unplug by pulling on the cord.
9. Do not handle the plug or carpet washer with wet hands.
10. Do not put any objects into openings or operate with openings blocked, keep them free of anything that may reduce airflow.
11. Keep hair, loose clothing, fingers and all parts of the body away from openings and moving parts.
12. Do not use the carpet washer on any glowing, burning or smoking particles.
13. Do not use without the solution tank and dirty water tank in place.
14. Do not use the vacuum without the dust bag in place.
15. Turn off all controls before unplugging.
16. Do not use to pick up flammable or combustible liquids such as petrol, or use in areas where they may be present.
17. Keep the unit on the floor.
18. Do not use an extension cord.
19. Do not attempt to remove blockages with sharp objects as they may cause damage.
20. Store indoors put away after use to prevent tripping accidents.

21. Using improper voltage may result in damage to the motor and possible injury to the user. The correct voltage is listed on the rating label.
22. A hazard may occur if the carpet washer runs over the power supply cord.
23. To prevent dirty water from running into motor, do not hold the appliance upside-down or lay on its side. Use appliance in normal vacuuming position.
24. Use extra care when cleaning on stairs.
25. Do not carry appliance while motor is running.

**NOTE: Carpets should be dry vacuumed thoroughly before washing.**

**NOTE: The unit must be unplugged from the mains socket outlet after use, and before cleaning or maintaining the unit.**



**IMPORTANT: This unit is not intended for commercial use.**

**PLEASE KEEP THESE INSTRUCTIONS FOR FURTHER USE.**

### 3. Preparing the Carpet

**! IMPORTANT:** Do not use the cleaner as a dry vacuum.

1. Vacuum carpet thoroughly. Use a vacuum cleaner with a revolving brushbar for best results.

2. Remove as much furniture from the room as possible. If unable to remove the furniture, place plastic or foil under and around the legs until the carpet has dried completely.

#### Helpful hints for cleaning carpet:

1. Only use Vax recommended carpet cleaner with this carpet washer.
2. Do not oversaturate carpet with cleaning solution while using the carpet washer.
3. For heavily soiled areas, additional applications may be necessary.
4. Allow plenty of time to dry carpet thoroughly.
5. Wipe cleaning solution from woodwork and wood to prevent any damage.
6. Try not to walk on carpet until it is completely dry.
7. After carpet is thoroughly dry, vacuum the carpet using a vacuum cleaner with a revolving brushbar.
8. Before cleaning, determine where to start and end, making sure not to walk over previously cleaned areas.

#### Check for colour fastness

Before cleaning carpet, test for colour fastness. Dampen a white cloth with solution. Test on a small inconspicuous area prior to washing. Gently rub the cloth over the area. Check each colour for colour bleeding. If the cloth remains clean, it should be safe to clean the carpet.

#### After cleaning

- Allow carpet to dry completely. Try not to walk on the carpet until it is dry.
- If it is necessary to walk on the carpet, place white towels on the areas to be walked on.
- If the carpet is not dry and the furniture must be placed back in the room, use plastic or foil under the furniture to prevent staining the carpet.
- Thoroughly clean the dirty water tank with warm (max 40°C) tap water.

### 4. Getting Ready to Wash

1. Unclip Container Release Clips (A) on both sides of machine (Fig.4/1).

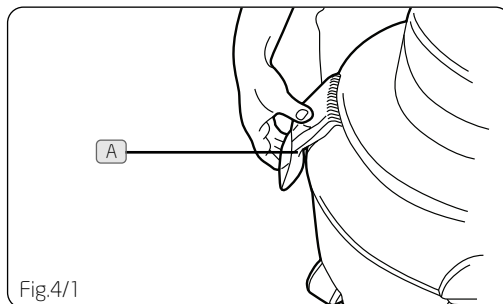

2. Lift off Motor Container to reveal Clean Water Tank (A) situated inside Dirty Water Tank (B) (Fig.4/2).

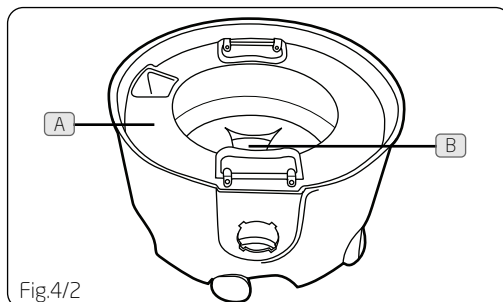

3. Remove Clean Water Tank (A) from inside the Dirty Water Tank and fill with warm (max 40°C) water to point indicated on the tank. Add 1 capful of Vax AAA solution per litre of water (unless otherwise stated on the bottle) (Fig 4/3).

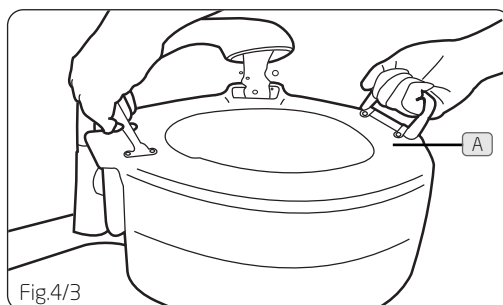

4. Replace Clean Water Tank (A) inside Dirty Water Tank (B) taking care to ensure that the space to allow the dirty water back into the tank is lined up with the Solution Port (C) (Fig.4/4).



Fig.4/4  
5. Replace Motor Container (A) ensuring that the Solution Pump Hose (B) is aligned with the hole in the Clean Water Tank (C) so that it goes inside when the Motor Container is clipped back into position (Fig.4/5).

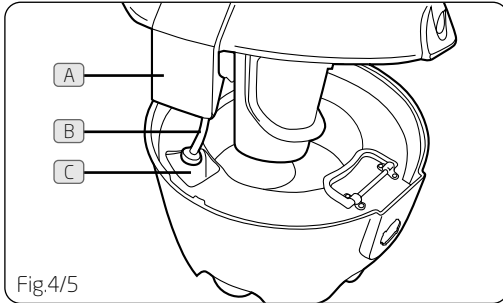
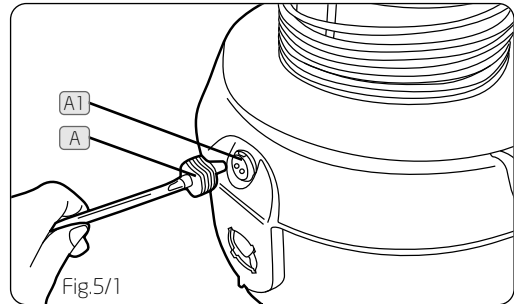

Fig.4/5  
**WARNING: Machine must not be plugged in during this stage.**

## 5. Assembly

1. Push solution tube to machine connector (A) firmly into Solution Port (A1). Twist solution tube connector (A1) a quarter turn to the right to lock into place (Fig.5/1).



2. Push hose connector (B) firmly into Hose Connection Port (B1). Twist to the right until hose connector locks into place (Fig.5/2).

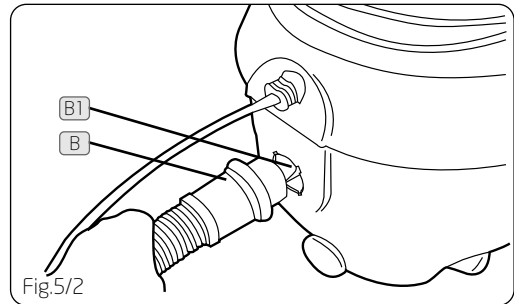

3. Push one end of the telescopic tube into the handle of the hose (Fig.5/3).

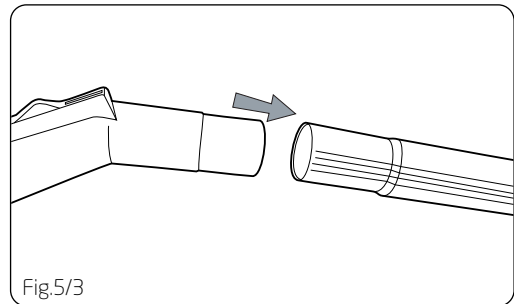

4. Wrap Solution Tube (A) around Hose (B). Ensure that the solution tube is wrapped loosely enough to allow the solution to flow freely through the tube (Fig.5/4).

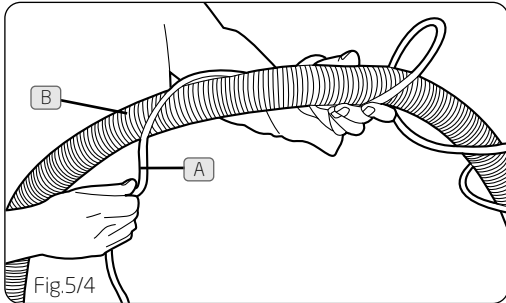

Fig.5/4

5. After wrapping the tube around the hose, affix Solution Tube (A) to Hose (B) using Clips provided (C) to hold it in place (Fig.5/5).

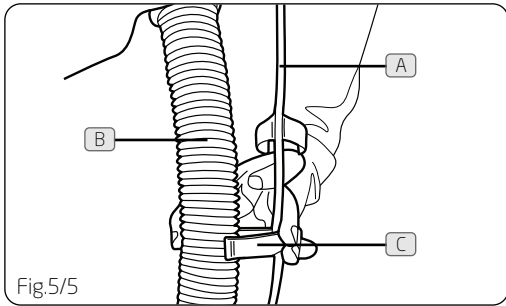

Fig.5/5

6. Push the other end of the telescopic tube into the wash head to be used and push the end of the solution tube onto the connection port on the Wash Head / Upholstery Tool (Fig.5/6).

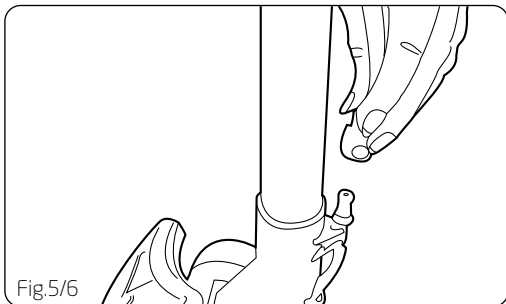

Fig.5/6

## 6. Usage

1. Plug in machine to power supply.
2. Press the red button to turn on the power.
3. Press the green button to activate the pump.

### Washing Carpets

1. On the Fibreflow wash head ensure that the rocker switch (A) is towards the back of the head to allow water to flow through the head (Fig.6/1).

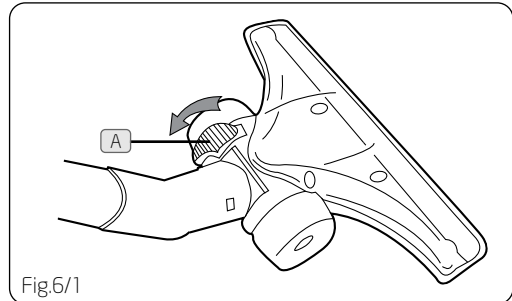

Fig.6/1

2. In order to help suck up excess water, the rocker switch (A) can be pushed to the front position on the Fibreflow wash head. This will prevent water flow, allowing excess water to be removed (Fig.6/2).

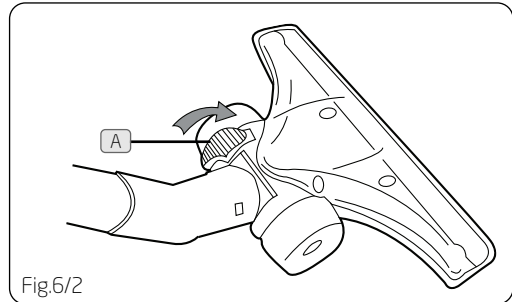

Fig.6/2

## 7. Maintenance

**!** **IMPORTANT:** Ensure that the machine is switched off and unplugged from the socket before carrying out any maintenance.

Cleaning the Pre-Motor Filter.

1. Remove the motor top from the unit, turn on its side and remove the float housing in an anti-clockwise direction to unscrew (Fig.7/1).

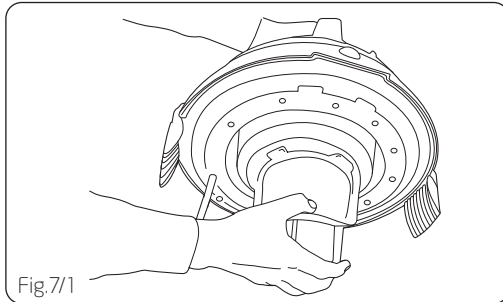

Fig.7/1

2. Remove the blue filter (Fig.7/2) and wash under a tap. Allow to dry thoroughly before replacing back into the machine. Replace with a new filter as necessary.

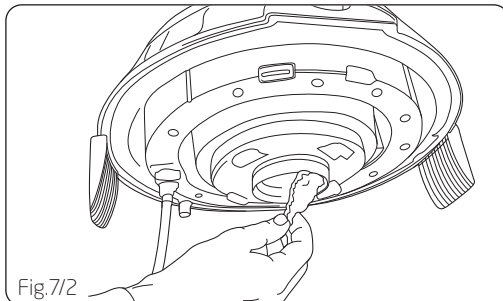

Fig.7/2

3. Turn the float housing in a clockwise direction until secure and place the motor top back onto the unit.

### Cleaning the Post-Motor Filter

1. Remove the filter housing at the back of the machine (Fig.7/3).

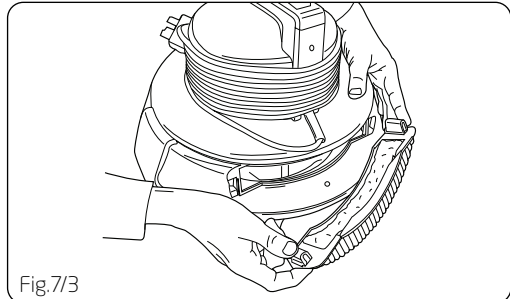

Fig.7/3

2. Remove the filter (Fig.7/4) and wash under a tap. Allow to dry thoroughly before replacing back into the machine.

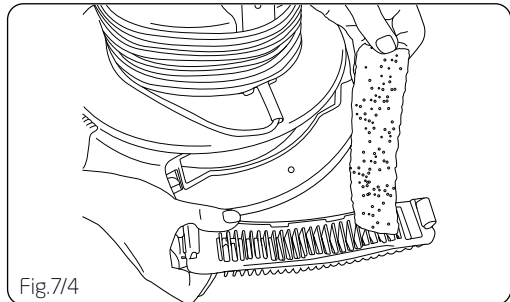

Fig.7/4

3. Once dry, put the filter back into the housing and place back into the machine.

www.vax.co.uk

## 8. Troubleshooting

**⚠ WARNING:** To reduce the risk of personal injury, unplug the vacuum cleaner before performing maintenance or troubleshooting checks.

### **PROBLEM: The cleaner won't run.**

**Cause:** Not properly plugged into electrical outlet.

**Solution:** Plug in firmly.

**Cause:** No electricity in electrical outlet.

**Solution:** Check fuse or breaker.

**Cause:** ON/off switch not turned on.

**Solution:** Push on/off switch to 'on'.

**Cause:** Blown fuse/tripped breaker.

**Solution:** Reset circuit breaker or replace fuse.

### **PROBLEM: Cleaner won't pick up/loss of suction.**

**Cause:** Dust bag not installed correctly.

**Solution:** Review dust bag removal and replacement.

**Cause:** Dust bag full or blocked.

**Solution:** Replace dust bag.

**Cause:** Clogged filter.

**Solution:** Remove filter and clean.

**Cause:** Blockage in hose.

**Solution:** Disconnect hose, remove the obstruction then re-fit.

### **PROBLEM: Cleaner/accessories won't pick up.**

**Cause:** Accessories not connected properly.

**Solution:** Refer to page 8 for fitting information.

**Cause:** The hose is clogged.

**Solution:** Remove hose and tools. Remove obstruction.

## 9. UK Service & Help

### **Vax Care 0870 6061248**

Monday-Friday 9.00am to 5.00pm.

An answerphone is available outside of these hours. Any queries or concerns about using the Vax, call the Vax Careline. Calls are charged at the UK national rate.

Please make a note of the serial number and model number of the carpet cleaner before calling. There are over 400 approved Vax Service Agents in the UK. For the nearest Service Agent, please call the Vax Careline.

**www.vax.co.uk**

## 10. Technical Specification

Voltage: 220-240V ~50Hz  
Wattage: 1300W  
Capacity: Clean water tank - 4 litres  
Dirty water tank - 5.2 litres  
Cord length: 7.5m  
Weight: 7.7kg

Subject to technical change without notice.



[www.vax.co.uk](http://www.vax.co.uk)

This page has been left intentionally blank

This page has been left intentionally blank



### EEC STATEMENT OF COMPLIANCE

Manufacturer/EEC importer: Vax Limited, hereby on our own responsibility, declare that the product VEW-01 Essentials carpet washer is manufactured in compliance with the following Directives:

**Safety:** 2006/95/EC Low Voltage Directive

**EMC:** 2004/108/EC Electromagnetic Compatibility Directive



Waste electrical products should not be disposed of with household waste. Please recycle where facilities exist. Check with your Local Authority or retailer for recycling advice.

Vax Ltd., Kingswood Road, Hampton Lovett, Droitwich, Worcestershire, WR9 0QH, UK  
email: [info@vax.co.uk](mailto:info@vax.co.uk) - website: [www.vax.co.uk](http://www.vax.co.uk)